

Kinetix 6000 Shunt Module

Catalog Number 2094-BSP2

Topic	Page
About the Kinetix 6000 Shunt Module	1
Important User Information	2
Before You Begin	3
Install the Kinetix 6000 Shunt Module	3
Connector Data	7
Power Wiring Requirements	8
Additional Resources	9

About the Kinetix 6000 Shunt Module

The Bulletin 2094 shunt module provides 200 W shunting capacity for applications where the internal Kinetix 6000 integrated axis (IAM) module or axis (AM) module shunt capacity is exceeded. The Kinetix 6000 shunt module is compatible with all 230V and 460V Kinetix 6000 drive systems and mounts on the Bulletin 2094 power rail.

IMPORTANT

Use the 2094-BSP2 shunt module in any single Kinetix 6000 power rail system and in common-bus applications where the IAM module is the common-bus leader drive. You cannot use the 2094-BSP2 shunt module in common-bus applications where the IAM module is the common-bus follower drive.

You cannot mount more than one 2094-BSP2 shunt module on the power rail.

Refer to the Kinetix 6000 Multi-axis Servo Drive User Manual, publication [2094-UM001](#), for detailed information on wiring, applying power, troubleshooting, and integration with ControlLogix, CompactLogix, or SoftLogix controller platforms.

Important User Information

Solid state equipment has operational characteristics differing from those of electromechanical equipment. Safety Guidelines for the Application, Installation and Maintenance of Solid State Controls (publication [SGL-1.1](#) available from your local Rockwell Automation sales office or online at <http://literature.rockwellautomation.com>) describes some important differences between solid state equipment and hard-wired electromechanical devices. Because of this difference, and also because of the wide variety of uses for solid state equipment, all persons responsible for applying this equipment must satisfy themselves that each intended application of this equipment is acceptable.





In no event will Rockwell Automation, Inc. be responsible or liable for indirect or consequential damages resulting from the use or application of this equipment.

The examples and diagrams in this manual are included solely for illustrative purposes. Because of the many variables and requirements associated with any particular installation, Rockwell Automation, Inc. cannot assume responsibility or liability for actual use based on the examples and diagrams.

No patent liability is assumed by Rockwell Automation, Inc. with respect to use of information, circuits, equipment, or software described in this manual.

Reproduction of the contents of this manual, in whole or in part, without written permission of Rockwell Automation, Inc., is prohibited.

Throughout this manual, when necessary, we use notes to make you aware of safety considerations.

<p>WARNING</p> 	<p>Identifies information about practices or circumstances that can cause an explosion in a hazardous environment, which may lead to personal injury or death, property damage, or economic loss.</p>
<p>IMPORTANT</p>	<p>Identifies information that is critical for successful application and understanding of the product.</p>
<p>ATTENTION</p> 	<p>Identifies information about practices or circumstances that can lead to personal injury or death, property damage, or economic loss. Attentions help you identify a hazard, avoid a hazard and recognize the consequences.</p>
<p>SHOCK HAZARD</p> 	<p>Labels may be on or inside the equipment (for example, drive or motor) to alert people that dangerous voltage may be present.</p>
<p>BURN HAZARD</p> 	<p>Labels may be on or inside the equipment (for example, drive or motor) to alert people that surfaces may reach dangerous temperatures.</p>

Before You Begin

Remove all packing material, wedges, and braces from within and around the components. After unpacking, check the item nameplate catalog number against the purchase order.

Parts List

Drive Component	Ships With
Shunt Module	<ul style="list-style-type: none"> • Wiring plug for an external shunt resistor (RC). • Wiring plug for the thermal switch (TS). • These installation instructions, publication 2094-IN004.

Install the Kinetix 6000 Shunt Module

These procedures assume you have prepared your panel, mounted your Bulletin 2094 power rail, and understand how to bond your system. For installation instructions regarding equipment and accessories not included here, refer to the instructions that came with those products.

SHOCK HAZARD



To avoid hazard of electrical shock, perform all mounting and wiring of the Bulletin 2094 power rail and drive modules prior to applying power. Once power is applied, connector terminals may have voltage present even when not in use.

ATTENTION



Plan the installation of your system so that you can perform all cutting, drilling, tapping, and welding with the system removed from the enclosure. Because the system is of the open type construction, be careful to keep any metal debris from falling into it. Metal debris or other foreign matter can become lodged in the circuitry, which can result in damage to components.

Connector pins on the Bulletin 2094 power rail are covered with a protective boot. To avoid damage to the power rail during installation, do not remove the protective boot until you are ready to mount your shunt module.

Determining Mounting Order

Mount the IAM, AM, shunt, and slot-filler modules in the order (left to right) as shown. Mount axis modules according to power utilization (highest to lowest) from left to right starting with the highest power utilization. If power utilization is unknown, position axis modules (highest to lowest) from left to right based on amp rating.

Module Mounting Order Example

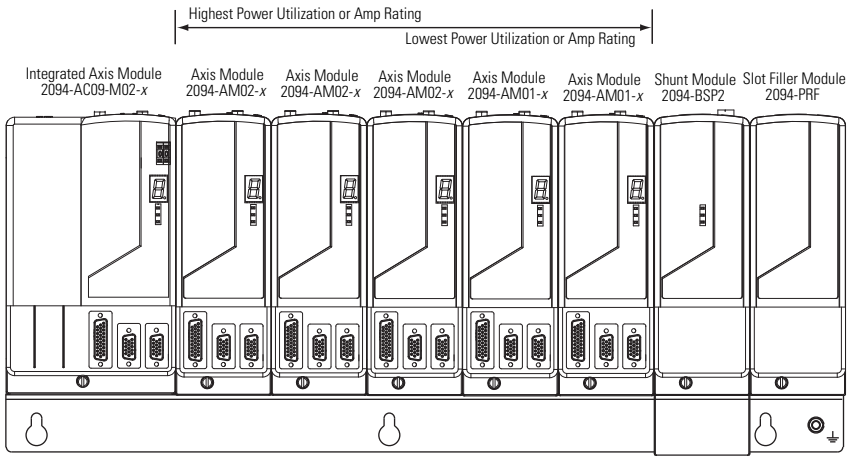

IMPORTANT

The IAM module must be positioned in the leftmost slot of the power rail. Position your AM modules, shunt module, and slot-filler modules to the right of the IAM module.

The shunt module must be installed to the right of the last AM module. Only slot-filler modules may be installed to the right of the shunt module.

Do not mount the shunt module on power rails with a follower IAM module. Common-bus follower IAM modules disable the internal, rail mounted, and external shunt modules.

SHOCK HAZARD



To avoid personal injury due to electrical shock, place a 2094-PRF slot-filler module in all empty slots on the power rail.

Any power rail connector without a module installed will disable the Kinetix 6000 system, however, control power will still be present.

Mount the Kinetix 6000 Shunt Module

Follow these steps to mount your 2094-BSP2 shunt module.

TIP

All modules mount to the power rail by using the same technique, however, the IAM module is shown in this example.

1. Remove the protective boot from the power rail connector.

IMPORTANT

The shunt module must be positioned to the right of the IAM and AM modules.

2. Remove the label (applied to back and side of module) covering the pins that mate with the power rail.

ATTENTION



To avoid damage to the pins located on the back of the shunt module and to make sure that module pins mate properly with the power rail, hang modules as shown in steps 3...6.

The power rail must be mounted vertically on the panel before hanging modules on the power rail. Do not mount modules if the power rail is horizontal.

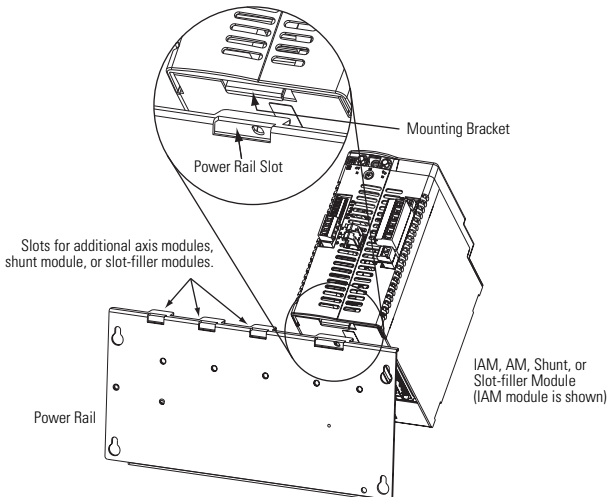
3. Hang the mounting bracket from the slot on the power rail.

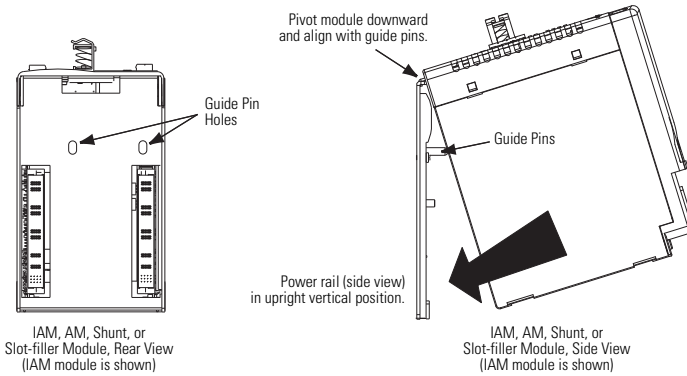

- Pivot module downward and align the guide pins on the power rail with the guide pin holes in the back of the module.



- Gently push the module against the power rail connectors and into the final mounting position.

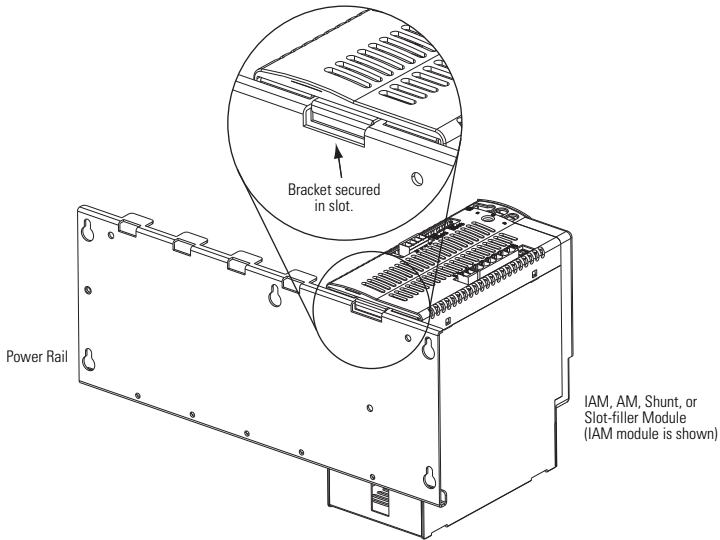

- Use 2.26 N•m (20 lb•in) torque to tighten the mounting screw.

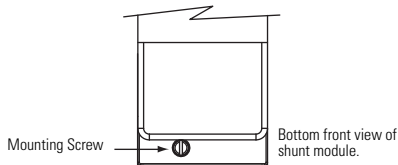

Connector Data

The Kinetix 6000 shunt module is compatible with all 230V and 460V drive systems.

Shunt Module Connectors and Indicators

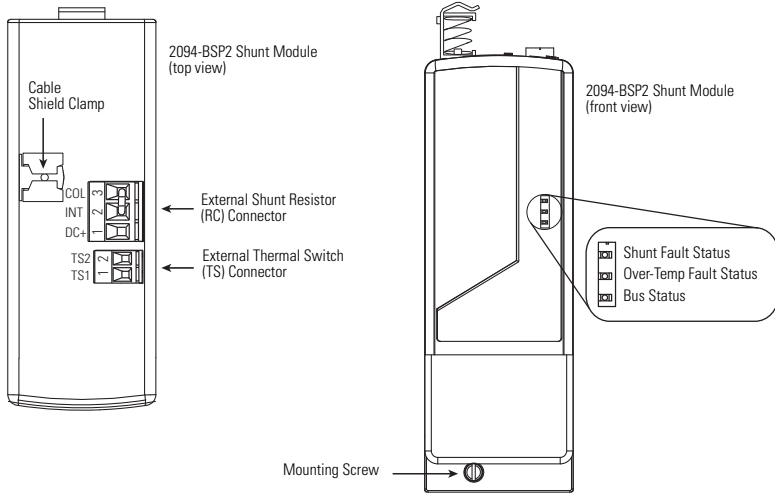

Shunt Module Connectors

Designator	Description	Connector
RC	External shunt resistor connector	Three-position connector housing
TS	Thermal switch connector	Two-position connector housing

External Shunt Resistor (RC) Connector Pinout

RC Pin	Description	Signal
1	External shunt resistor connection	DC+
2	Internal shunt connection	INT
3	Shunt collector connection	COL

External Thermal Switch (TS) Connector Pinout

TS Pin	Description	Signal
1	External passive shunt module thermal switch connections	TS1
2		TS2

Power Wiring Requirements

IMPORTANT

The National Electrical Code and local electrical codes take precedence over the values and methods provided.

Shunt Module Power Wiring Requirements

Connections	Terminals		Recommended Wire Size mm ² (AWG)	Torque Value N•m (lb•in)
	Pin	Signal		
1394-SRxxxx External passive shunt module	RC-1	DC+	10 (8) ⁽¹⁾	1.2...1.5 (10.6...13.2)
	RC-2	INT		
	RC-3	COL		
Thermal switch	TS-1	TS1	0.75 (18)	0.22...0.25 (1.9...2.2)
	TS-2	TS2		

⁽¹⁾ 105 °C (221 °F), 600V.

Using the default jumper settings, the Bulletin 2094 shunt module's (200 W) internal resistor is enabled and the thermal switch circuitry is not used. Remove the RC connector jumper when wiring to a Bulletin 1394 external shunt module. Remove the TS connector jumper when wiring to the 1394-SR36AF thermal-switch terminals. Refer to the Kinetix Motion Control Selection Guide, publication [GMC-SG001](#), for Bulletin 1394 shunt module catalog numbers. Refer to the Kinetix 6000 Multi-axis Servo Drive User Manual, publication [2094-UM001](#), for interconnect diagrams.

Shunt Module Jumper Settings

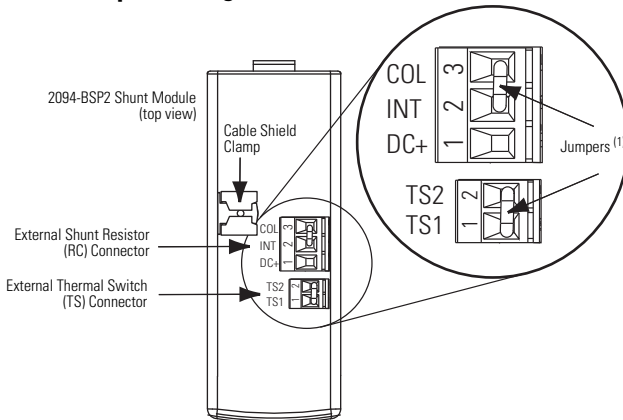

⁽¹⁾ These are the default jumper settings. Refer to External Shunt Modules Installation Instructions, publication [2090-IN004](#), when removing these jumpers and wiring to a Bulletin 1394 external shunt module.

Additional Resources

These documents contain additional information concerning related Rockwell Automation products.

Resource	Description
Kinetix 6000 Multi-axis Servo Drive User Manual, publication 2094-UM001	Information on installing, configuring, startup, troubleshooting, and applications for your Kinetix 6000 servo drive system.
Kinetix 6000 Power Rail Installation Instructions, publication 2094-IN003	Information on the installation of your Bulletin 2094 power rail.
1394 Shunt Modules Fuse Replacement Kit Installation Instructions, publication 1394-6.6	Information on replacing the fuse in a Bulletin 1394 shunt module.
External Shunt Modules Installation Instructions, publication 2090-IN004	Information on installing Bulletin 1394 external shunt modules with Kinetix 6000 drive systems.
System Design for Control of Electrical Noise Reference Manual, publication GMC-FM001	Information, examples, and techniques designed to minimize system failures caused by electrical noise.
EMC Noise Management DVD, publication GMC-SP001	
Kinetix Motion Control Selection Guide, publication GMC-SG001	Specifications, motor/servo-drive system combinations, and accessories for Kinetix motion control products.
Rockwell Automation Configuration and Selection Tools, website http://ab.com/e-tools	Online product selection and system configuration tools, including AutoCAD (DXF) drawings.
Rockwell Automation Product Certification, website http://rockwellautomation.com/products/certification	For declarations of conformity (DoC) currently available from Rockwell Automation.
National Electrical Code, published by the National Fire Protection Association of Boston, MA	An article on wire sizes and types for grounding electrical equipment.
Rockwell Automation Industrial Automation Glossary, publication AG-7.1	A glossary of industrial automation terms and abbreviations.

You can view or download publications at <http://literature.rockwellautomation.com>. To order paper copies of technical documentation, contact your local Rockwell Automation distributor or sales representative.

Rockwell Automation Support

Rockwell Automation provides technical information on the Web to assist you in using its products. At <http://support.rockwellautomation.com>, you can find technical manuals, a knowledge base of FAQs, technical and application notes, sample code and links to software service packs, and a MySupport feature that you can customize to make the best use of these tools.

For an additional level of technical phone support for installation, configuration and troubleshooting, we offer TechConnect support programs. For more information, contact your local distributor or Rockwell Automation representative, or visit <http://support.rockwellautomation.com>.

Installation Assistance

If you experience a problem within the first 24 hours of installation, please review the information that's contained in this manual. You can also contact a special Customer Support number for initial help in getting your product up and running.

United States	1.440.646.3434 Monday – Friday, 8 a.m. – 5 p.m. EST
Outside United States	Please contact your local Rockwell Automation representative for any technical support issues.

New Product Satisfaction Return

Rockwell Automation tests all of its products to ensure that they are fully operational when shipped from the manufacturing facility. However, if your product is not functioning and needs to be returned, follow these procedures.

United States	Contact your distributor. You must provide a Customer Support case number (call the phone number above to obtain one) to your distributor in order to complete the return process.
Outside United States	Please contact your local Rockwell Automation representative for the return procedure.

Allen-Bradley, CompactLogix, ControlLogix, Kinetix, Rockwell Automation, SoftLogix, and TechConnect are trademarks of Rockwell Automation, Inc.

Trademarks not belonging to Rockwell Automation are property of their respective companies.

www.rockwellautomation.com

Power, Control and Information Solutions Headquarters

Americas: Rockwell Automation, 1201 South Second Street, Milwaukee, WI 53204-2496 USA, Tel: (1) 414.382.2000, Fax: (1) 414.382.4444

Europe/Middle East/Africa: Rockwell Automation, Vorstlaan/Boulevard du Souverain 36, 1170 Brussels, Belgium, Tel: (32) 2 663 0600, Fax: (32) 2 663 0640

Asia Pacific: Rockwell Automation, Level 14, Core F, Cyberport 3, 100 Cyberport Road, Hong Kong, Tel: (852) 2887 4788, Fax: (852) 2508 1846

Publication 2094-IN004E-EN-P — June 2008

PN 313666-P05

Supersedes Publication 2094-IN004D-EN-P — September 2006

Copyright © 2008 Rockwell Automation, Inc. All rights reserved. Printed in the U.S.A.